

Costing for: **Typical Flue Detail Costing**
House type House with 200mm I.D. Flue
Customer ref. Chimney Height 7013
Site
Plot number

Costing ref **SJ 200ID-7m-offset-23A**
Date 16 October 2023
By SJ
Price list October 2023

Components

Dunbrik A1 concrete flue liner system

	Product code	Qty	Prices each	Disc %	Cost £
Throat lintel/gather unit 800mm wide	200TL800	1	94.75		94.75
200mm flue liner bend 22.5 degrees	200B	2	18.29		36.58
200mm flue liner 600mm tall	200L600	8	18.74		149.92
200mm flue liner 230mm tall	200L230	2	11.21		22.42
200mm flue liner 150mm tall	200L150	4	8.85		35.40
Cannon pot 450mm tall red	Cann450R	1	50.90		50.90
Flue liner sealant 310ml	Dunseal	6	6.68		40.08
Infill aggregate 22kg mix for void	Dunfil	18	6.98		125.64
Flue notice plate	Plate	1	7.73		7.73
Topguard birdguard cowl 260 tall red	TG260R	1	101.36		101.36

Total for system components

Cost ex-works	664.78
Delivery charge	60.00
Goods	£ 724.78
VAT @ 20%	144.96
Total	£ 869.74

Additional products (if required)

Smoke pellet tube	Smoke	1	11.34		11.34
310ml Skeleton Gun	Sealgun	1	6.40		6.40
Red polypropylene air brick 220mm x 72mm	REDG930	3	0.92		2.76
High impact styrene black cavity sleeve 218mm x 72mm	CSG935	3	5.03		15.09

Plus VAT @ 20%

All prices are ex-works, valid for 30 days and are subject to VAT.
Charge for individually plotting multiple flue orders is £30 per plot.
Free delivery for orders over £1,000 nett invoice value (ex-Vat) to UK mainland excluding the Highlands of Scotland (POA).
All trading is subject to our standard conditions of sale (copy available).

Notes

This flue costing is based on information provided. Please have your architect check the costing to your drawings prior to ordering, to ensure that it meets with your requirements. Please also check the pot/terminal style and colour.

For construction guidance refer to the flue illustration and the installation guide available on our website dunbrikflues.co.uk

The infill is based on a 300mm x 352mm void between the liners and masonry

Please ensure that the flue and chimney are constructed in accordance with Building regulations part J

Notes

Chimney Height of 7013mm from FFL to underside of chimney pot.

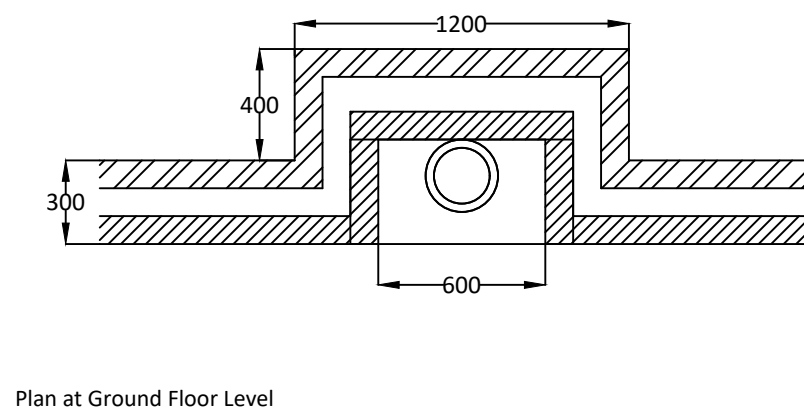
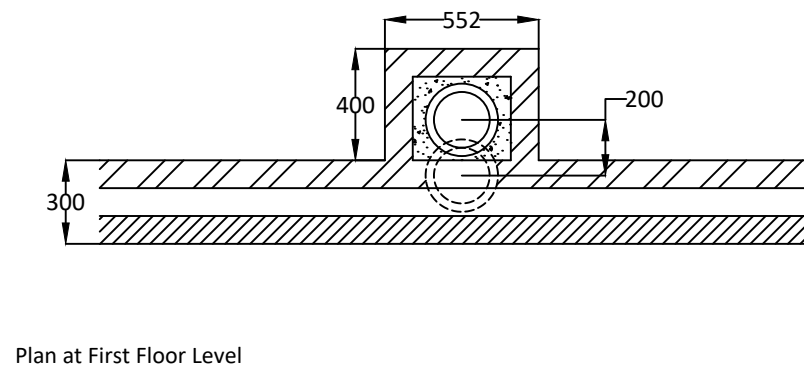
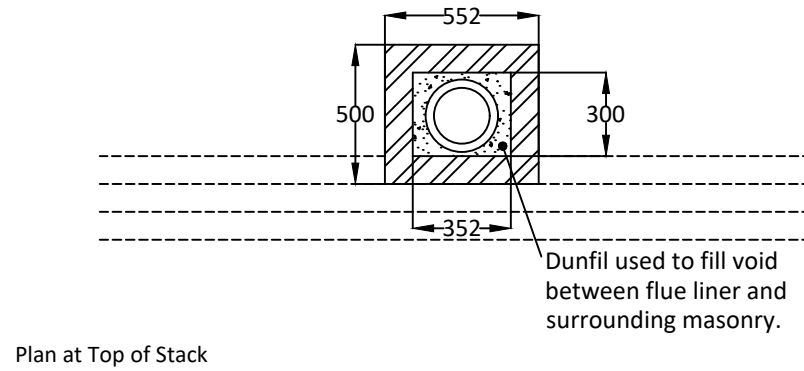
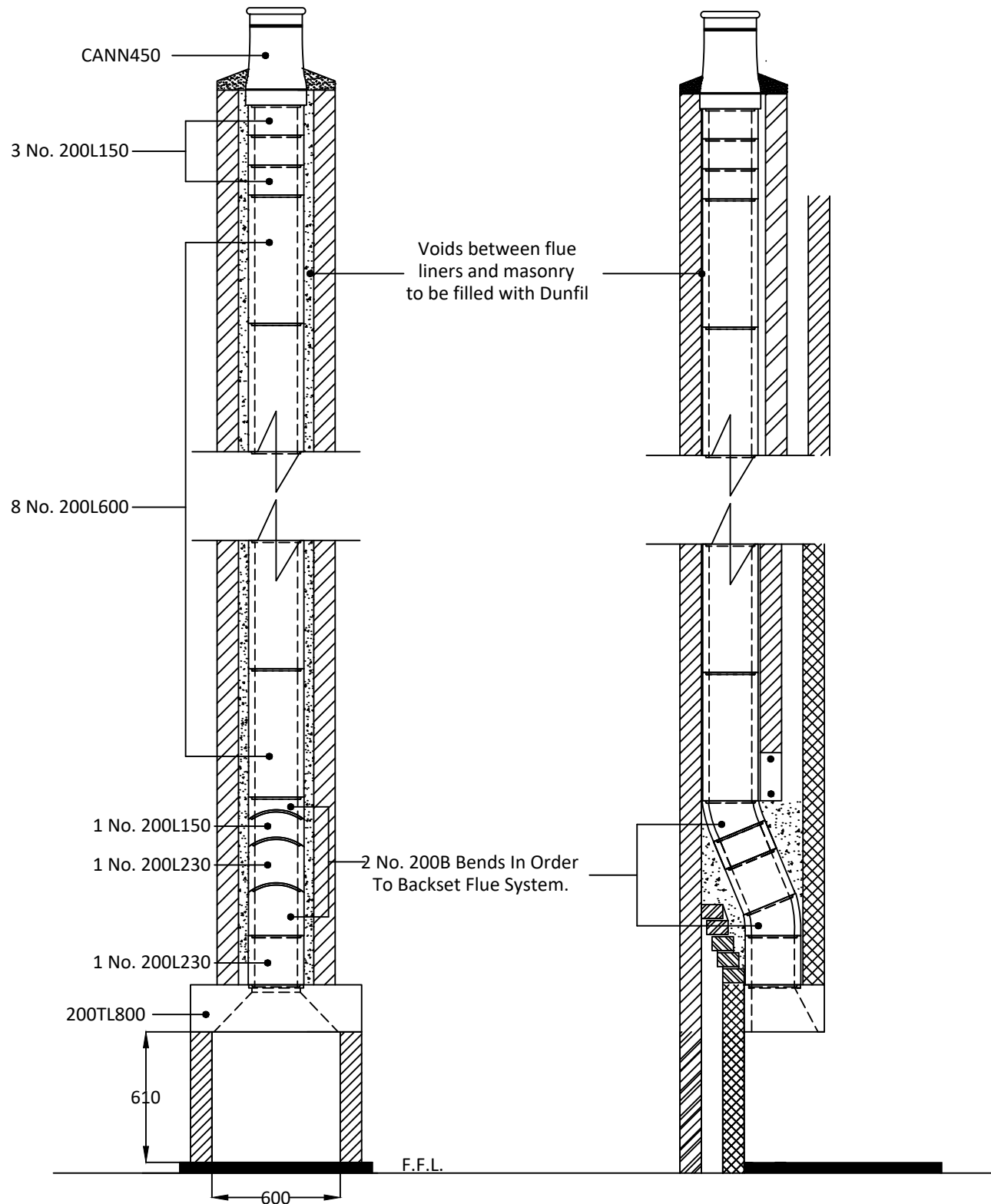

Please have your architect check this typical flue detail to your drawings to ensure it meets both your requirements and current building regulations.

ALL DIMENSIONS ARE SHOWN IN MILLIMETRES NOT TO SCALE

The checklist is based on Building Regulations ADJ Appendix A. with Dunbrik flue liner system data. The builder/installer should insert details of the actual fireplace opening sizes, actual ventilation installed and any variations to the usual data.

For	Typical Flue Detail Costing	Costing ref	SJ 200ID-7m-offset-23A
Site at		Plot number	
System	Dunbrik 200mm id A1 concrete flue liners	House type	House with 200mm I.D. Flue
Date	16 Oct 2023	Customer ref.	Chimney Height 7013

Checklist for hearths, fireplaces, flues and chimneys

This checklist can help you to ensure hearths, fireplaces, flues and chimneys are satisfactory. If you have been directly engaged, copies should also be offered to the client and to the Building Control body to show what you have done to comply with the requirements of part J. If you are a sub-contractor, a copy should be offered to the main contractor.

Items listed in ADJ Appendix A	Details for builder to complete or amend	Amend
1 Building address, where work has been carried out		
2 Identification of hearth, fireplace, chimney or flue.	Fireplace in lounge	
3 Firing capability: solid fuel/gas/oil/all	All	
4 Intended type of appliance. State type or make. If open fire give finished fireplace opening dimensions.	For domestic fuel stove up to a 200mm external diameter flue outlet pipe	
5 Ventilation provisions for the appliance State type and area of permanently open air vents	Through wall ventilation As per stove manufacturers requirements	
6 Chimney or flue construction a) State the type or make and whether new or existing. b) Internal flue size (and equivalent flue height, where calculated natural draught gas appliances only). c) If liners are used confirm they are correctly jointed in accordance with manufacturers instructions and state jointing materials used. d) If an existing chimney has been refurbished with a new liner, type or make of liner fitted. e) Details of flue outlet terminal Outlet detail Complies with: f) Number and angle of bends. g) Provision for cleaning and recommended frequency.	New masonry chimney with: Dunbrik A1 concrete flue liners to BSEN1857 200mm internal diameter Tongue downwards into rebate and joined with Dunseal fireproof mortar Cannon pot 450mm tall BSEN13502:2002 2 bends ref 200B at 22.5 degrees Annually via stove	
7 Hearth. Form of construction. New or existing	New As diagram 25 in ADJ	
8 Inspection and testing after completion Test (Appendix E in AD J 2002) and results Flue inspection results Visual Sweeping Coring ball Smoke Appliance (where included) Spillage	Tests carried out by:	

I/We the undersigned confirm that the above details are correct. In my opinion, these works comply with the relevant requirements in Part J of Schedule 1 to the Building Regulations.

Print name & title	_____	Profession	_____
Capacity	_____	Tel no	_____
Address	_____	Postcode	_____
Signed	_____	Date	_____
Registered membership of (e.g. Gas Safety, OFTEC, HETAS, NACE, NACS)			